

IKO

Precision Positioning Table L

TSL

U.S. PATENTED

The table with capillary plates has been newly released.



CAT-57124

Long stroke Series with Higher

Capillary plate incorporated type that can achieve long-term maintenance-free operation has been newly released.



Accuracy



IKO

Precision Positioning Table L

TSL

A wide range of size variations

Stable high running accuracy

Lightweight and long stroke

IKO Precision Positioning Table L TSL

IKO Precision Positioning Table L is a lightweight and long stroke positioning table consisting of a slide table and a bed made of a high-strength aluminum alloy. Both high precision and large allowable load mass are achieved by incorporating two sets of IKO Linear Way in parallel and using a precision ball screw in the feed mechanism. Also, by attaching capillary plates, the maintenance work including grease-up for Linear Way and the ball screw can be greatly reduced. A wide range of variations in table size and stroke length and a series of XY bracket permit constructing a system such as a crossed type robot easily according to each application. Precision Positioning Table L is widely used as a high accuracy positioning mechanism in assembling machines, processing machines, and measuring instruments, and its superior performance has been proved in the field.

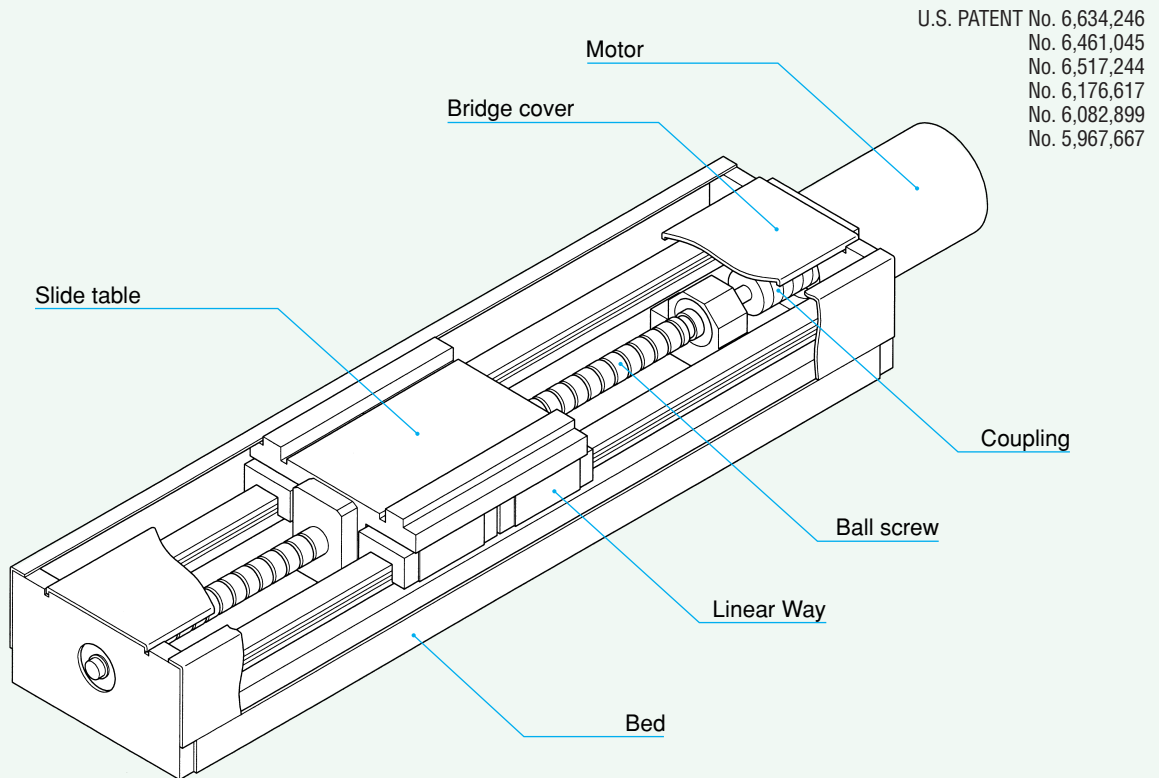

Structure of Precision Positioning Table L

High accuracy, lightweight, and long stroke positioning table

Features of TSL

High running accuracy and high positioning accuracy

High running accuracy is achieved by incorporating two sets of Linear Way in parallel. High accuracy positioning can be performed in combination with a precision ball screw.

Capillary plate

Capillary plates made by impregnating lubricant can be attached. This reduces the man-hours for maintenance work including grease-up for Linear Way and the ball screw.

Lightweight and long stroke

A slide table and a bed made of a high-strength aluminum alloy are used for reducing the total weight. Stroke lengths of up to 1000 mm are available as the series.

A wide range of size variations that enables easy assembling of multi-axis system

Four sizes of a table width of 90 mm to 220 mm are available as the series.
A multi-axis system can be easily constructed with an XY bracket.

Variations and positioning accuracy of TSL

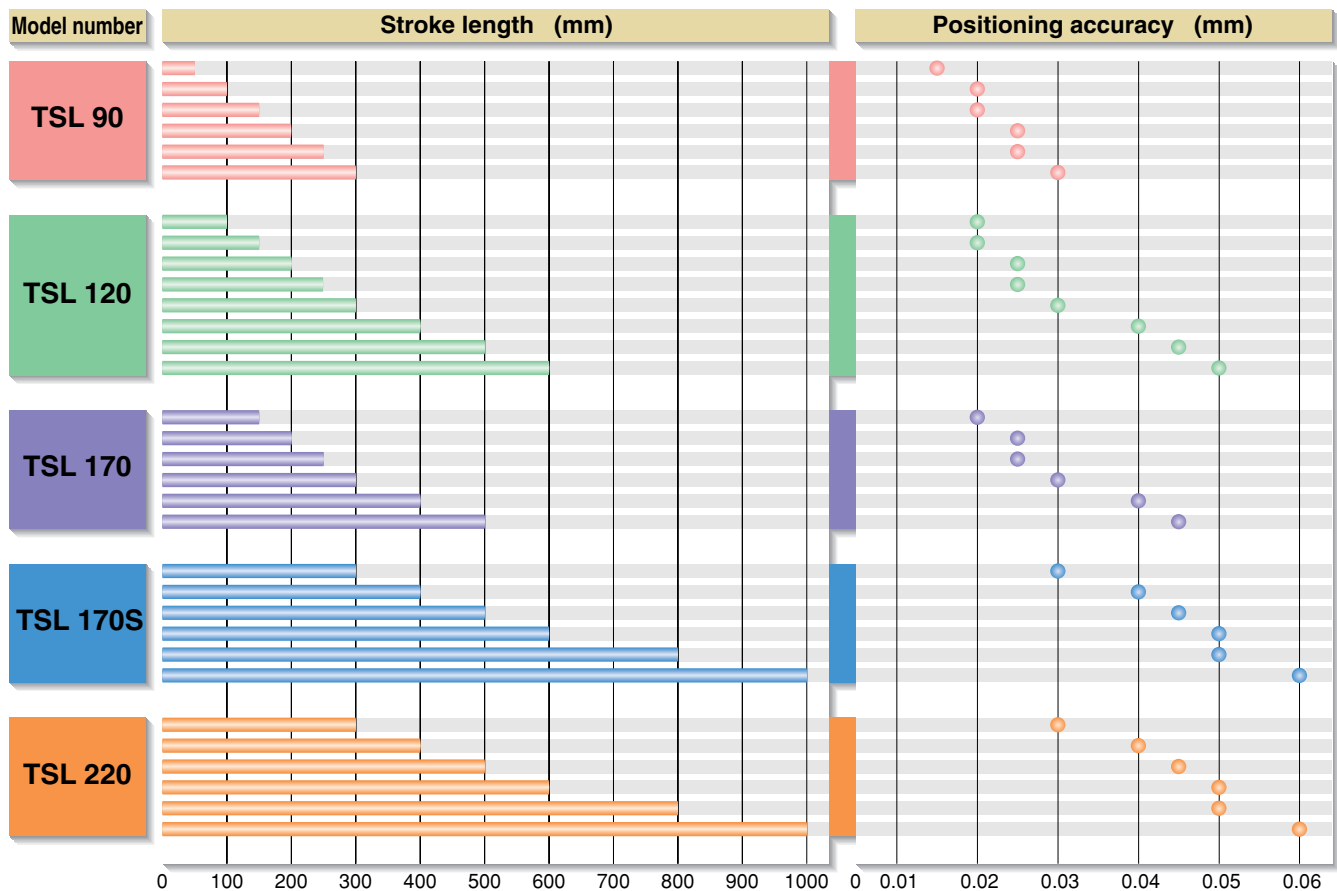

Identification Number

Example of identification number

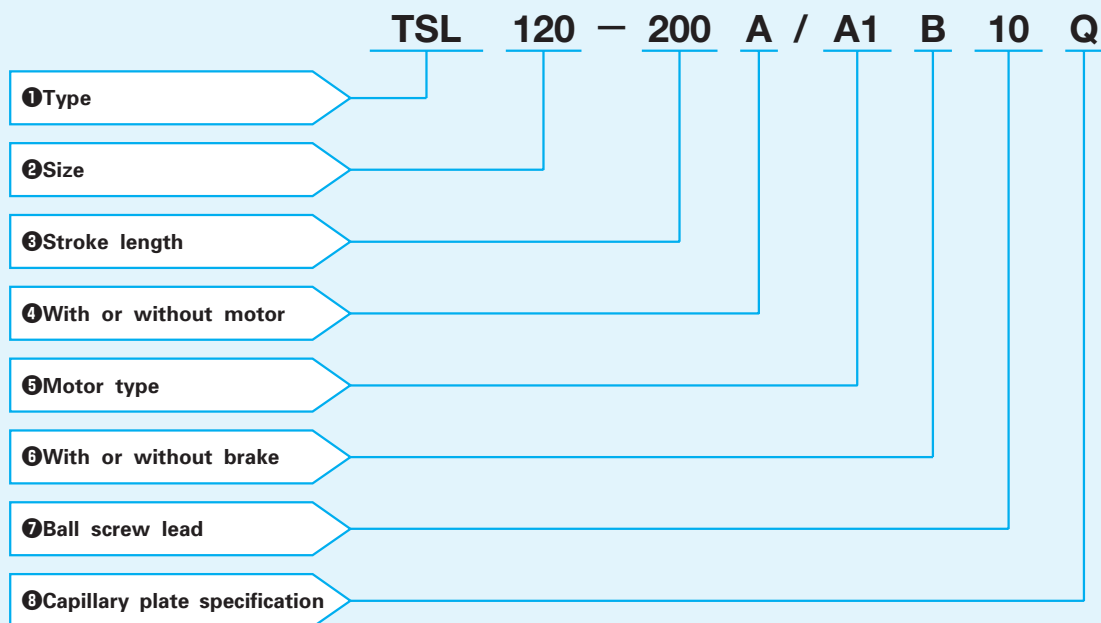

1 Type

TSL : Precision Positioning Table L

2 Size

The size indicates a table width.
Select a size and a table width in Table 1.

3 Stroke length

Select an applicable size and an applicable stroke length in Table 1.

Table 1 Sizes, table widths, and stroke lengths

Size	Table width mm	Stroke length mm
TSL 90	90	50 ⁽¹⁾ , 100, 150, 200, 250, 300
TSL 120	120	100, 150, 200, 250, 300, 400, 500, 600
TSL 170	170	150, 200, 250, 300, 400, 500
TSL 170S	170	300, 400, 500, 600, 800, 1000
TSL 220	220	300, 400, 500, 600, 800, 1000

Note⁽¹⁾ : The specification with capillary plates is not available.

Remark : The stroke length for the specification with capillary plates is shorter than the indicated stroke length.

④ With or without motor

No symbol : Without brake When the motor is prepared by the customer,
A : With motor specify "without motor" (no symbol) .

⑤ Motor type

Select a motor type out of the motor codes shown in Table 2.
When "without motor" (no symbol) is selected in Item ④ With or without motor, the motor attachment and coupling applicable to the specified motor will be mounted. If the motor attachment which is applicable to NEMA motor or other motors, consult .

Table 2 Motor types and motor codes

Size	Motor type	
	AC servo motor	Stepping motor
TSL 90	A1	K5
TSL 120		
TSL 170		
TSL 170S		
TSL 220	A2	K7

⑥ With or without brake

No symbol : Without brake If a motor with brake is required, specify "with
B : With brake motor" (symbol B) .

⑦ Ball screw lead

5 : Lead 5mm
10 : Lead 10mm

⑧ Capillary plate specification

No symbol : Without capillary plates The ball screw and capillary plates are
Q : With capillary plates mounted in Linear Way. The table with
capillary plates has a shorter stroke length.

Explanation of capillary plate

The capillary plate is a lubricating part in which a lot of lubricant is impregnated in continuous porous sintered resin. When it slides in contact with the ball screw shaft and track rail raceway, the lubricant in the plate oozes out properly onto the raceway at all times so that the re-lubrication interval can be made longer, thereby reducing the man-hours required for maintenance work. This capillary plate is useful as a means for prevention against a loss of grease at hard-to-lubricate positions.

Accuracy and Maximum Speed

Table 3 shows the accuracy of Precision Positioning Table L and Table 4 shows the maximum speed. The maximum speed shown in Table 4 is a value when the standard motor is used. For the actual maximum speed, it is necessary to examine the operating pattern in accordance with the applied motor, the load conditions, etc.

Table 3 Accuracy

unit : mm

Size	Stroke length	Positioning accuracy	Repeatability	Parallelism in table motion B	Backlash
TSL 90	50	0.015	±0.002	0.020	0.003
	100	0.020		0.030	
	150				
	200	0.025		0.040	
	250				
	300				
TSL 120	100	0.020	±0.002	0.030	0.003
	150	0.025			
	200				
	250	0.030		0.040	
	300				
	400				
	500	0.045		0.050	
	600	0.050			
TSL 170	150	0.020	±0.002	0.030	0.003
	200	0.025			
	250				
	300	0.030		0.050	
	400				
	500				
500	0.045				
TSL 170S TSL 220	300	0.030	±0.002	0.040	0.003
	400	0.040		0.050	
	500	0.045			
	600	0.050		0.070	
	800				
	1000	0.060			

Table 4 Maximum speed

Motor type	Size	Stroke length mm	Motor speed r/min	Maximum speed mm/s	
				Lead 5mm	Lead 10mm
AC servo motor	TSL 90	—	3000	250	500
	TSL 120				
	TSL 170				
	TSL 170S	600 or less	3000	250	500
	TSL 220	800	2990	249	498
		1000	2030	169	338
Stepping motor	TSL 90	—	1800	150	300
	TSL 120				
	TSL 170				
	TSL 170S				
	TSL 220				

Maximum Load Mass

Maximum load masses of IICO Precision Positioning Table L are shown in Table 5. The maximum load mass is a reference value for maximum mass that can be mounted on the table used horizontally and differs with each load mass position (height H and length L).

Table 5 Maximum load mass

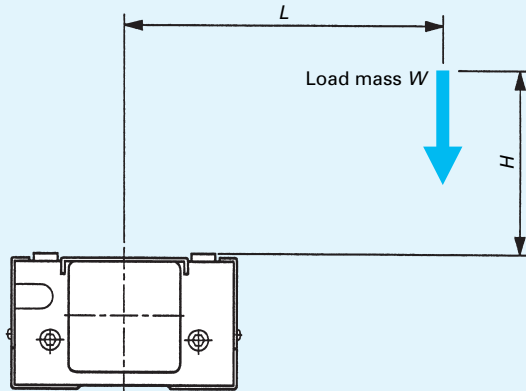

unit : kg

Size	Height H mm	Length L mm								
		0	100	200	300	400	500	600	800	1000
TSL 90	0	27	15	8.5	5.9	4.5	3.7	3.1	2.3	1.9
	200	27	14	8.3	5.8	4.5	3.7	3.1	2.3	1.9
	400	22	12	7.8	5.6	4.4	3.6	3.0	2.3	1.9
	600	16	10	7.2	5.4	4.3	3.5	3.0	2.3	1.9
TSL 120	0	99	89	52	36	28	23	19	15	12
	200	99	81	50	36	28	23	19	15	12
	400	99	68	46	34	27	22	19	14	12
	600	83	58	42	32	26	22	18	14	12
TSL 170	0	98	98	64	45	35	29	24	19	15
	200	98	93	60	44	34	28	24	18	15
	400	98	76	54	41	33	28	24	18	15
	600	83	62	48	38	31	26	23	18	15
TSL 170S	0	110	110	73	53	41	34	29	22	18
	200	110	110	72	52	41	34	28	22	18
	400	110	100	68	51	40	33	28	22	18
	600	110	91	64	49	39	33	28	22	18
TSL 220	0	110	110	110	110	110	89	76	59	48
	200	110	110	110	110	110	88	75	58	47
	400	110	110	110	110	100	85	74	57	47
	600	110	110	110	110	96	82	71	56	46

Remark : The above values are obtained by calculating the mass for which the rating life of the ball screw or linear motion rolling guide becomes 18000 hours when the table is continuously operated at the maximum speed (for each size), and 0.2s each, at acceleration, and at deceleration.

1N=0.102kgf=0.2248lbs.
1mm=0.03937inch

Table Inertia and Starting Torque

The table inertia and starting torque of **IKO** Precision Positioning Table L are shown in Table 6 and the standard motor types are shown in Table 7.

Table 6 Table inertia and starting torque

Size	Stroke length mm	Table inertia J_T $\times 10^{-5} \text{kg} \cdot \text{m}^2$		Starting torque T_0 ⁽²⁾ N-m
		Lead 5mm	Lead 10mm	
TSL 90	50 ⁽¹⁾	0.20	0.33	0.05 (0.07)
	100	0.25	0.38	
	150	0.28	0.40	
	200	0.33	0.45	
	250	0.35	0.48	
	300	0.40	0.53	
TSL 120	100	1.3	1.7	0.06 (0.08)
	150	1.5	1.9	
	200	1.7	2.1	
	250	1.9	2.3	
	300	2.1	2.5	
	400	2.4	2.9	
	500	2.8	3.3	
TSL 170	150	1.4	1.8	0.06 (0.08)
	200	1.6	2.0	
	250	1.8	2.2	
	300	2.0	2.4	
	400	2.3	2.8	
	500	2.7	3.2	
TSL 170S	300	6.9	7.4	0.10 (0.11)
	400	8.1	8.6	
	500	9.3	9.8	
	600	11	11	
	800	13	14	
	1000	15	16	
TSL 220	300	7.5	8.5	0.10 (0.11)
	400	8.7	9.7	
	500	9.9	11	
	600	11	12	
	800	14	15	
	1000	16	17	

Note⁽¹⁾ : The type with capillary plates is not available.

⁽²⁾ : The value in () is the starting torque for the type with capillary plates.

Table 7 Types of standard motor

Size	Motor type	With or without brake	Motor code	Model	Remark
TSL 90 TSL 120	AC servo motor	Without brake	A1	SGM-01B512	Yaskawa Electric Corporation
		With brake	A1B	SGM-01B512B	
TSL 170 TSL 170S	Stepping motor	Without brake	K5	PK566-A	Oriental Motor Co., Ltd.
		With brake	K5B	PK566-A-A25	
TSL 220	AC servo motor	Without brake	A2	SGM-02B512	Yaskawa Electric Corporation
		With brake	A2B	SGM-02B512B	
	Stepping motor	Without brake	K7	PK596-A	Oriental Motor Co., Ltd.
		With brake	K7B	PK596-A-A25	

Sensor Specifications

A sensor timing chart for Precision Positioning Table L without capillary plates is shown in Table 8. Table 9 shows a sensor timing chart for the table with capillary plates.

Table 8 Sensor timing chart (for the type without capillary plates)

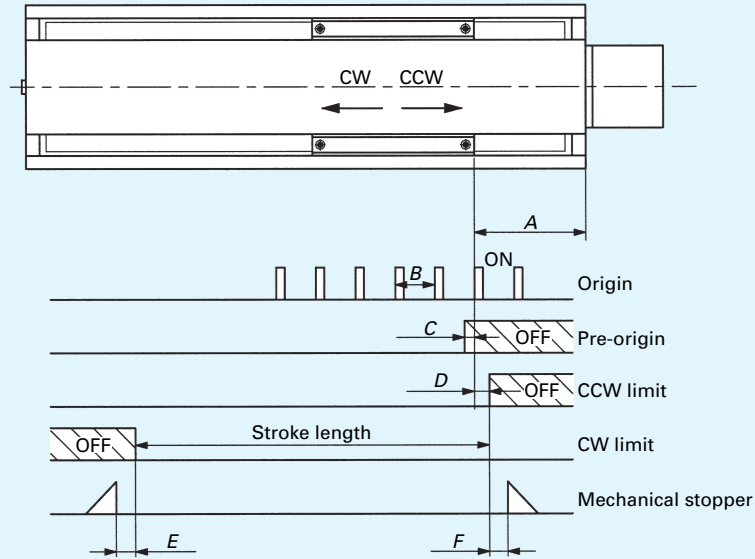

unit : mm

Size	Ball screw lead	A	B	C	D	E	F
TSL 90	5	50	5	3	20	5	5
	10		10	7			
TSL 120	5	60	5	3	20	15	15
	10		10	7			
TSL 170	5	45	5	3	20	3	3
	10		10	7			
TSL 170S	5	60	5	3	20	5	5
	10		10	7			
TSL 220	5	60	5	3	20	5	5
	10		10	7			

Remark : When the AC servo motor is selected, no origin sensor is attached. Use the C phase or Z phase signal of the encoder.

Table 9 Sensor timing chart (for the type with capillary plates)

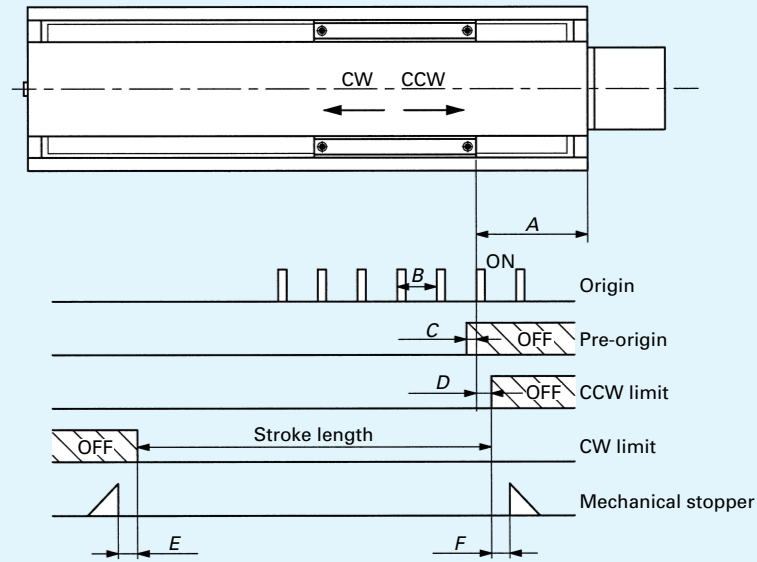

unit : mm

Size	Ball screw lead	A	B	C	D	E	F
TSL 90	5	60	5	3	20	5	5
	10		10	7			
TSL 120	5	55	5	3	20	5	5
	10		10	7			
TSL 170	5	60	5	3	20	5	5
	10		10	7			
TSL 170S	5	60	5	3	20	5	5
	10		10	7			
TSL 220	5	60	5	3	20	5	5
	10		10	7			

Remark : When the AC servo motor is selected, no origin sensor is attached. Use the C phase or Z phase signal of the encoder.

XY Bracket

IKO Precision Positioning Table L can configure various combinations of two axes by using the XY brackets (made of aluminum alloy) shown in Fig. 2 and Fig. 3. When ordering any of them, specify it by its model number.

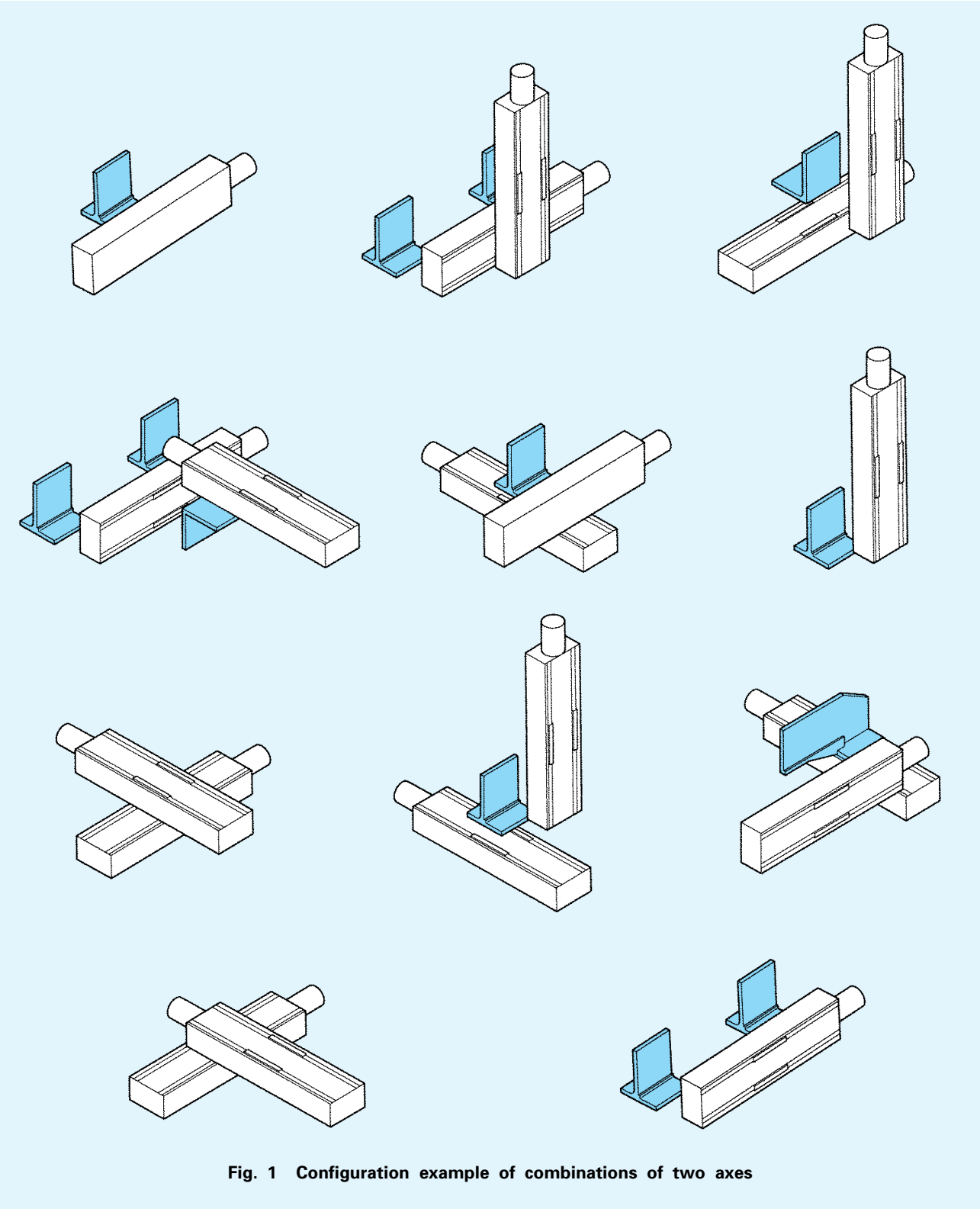
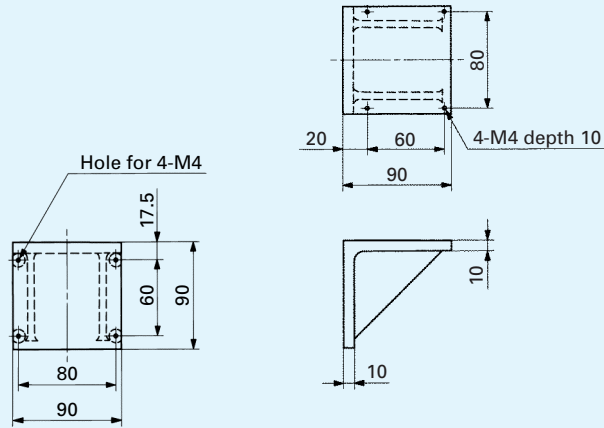
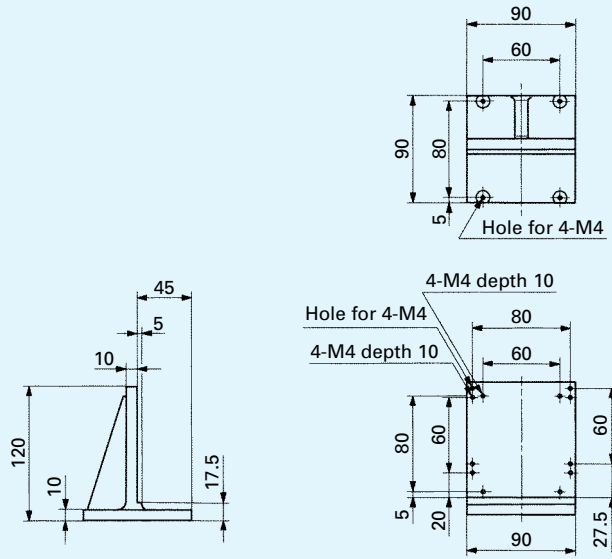

Fig. 1 Configuration example of combinations of two axes

●TSL90-AGL



●TSL90-AGI



●TSL90-AGT

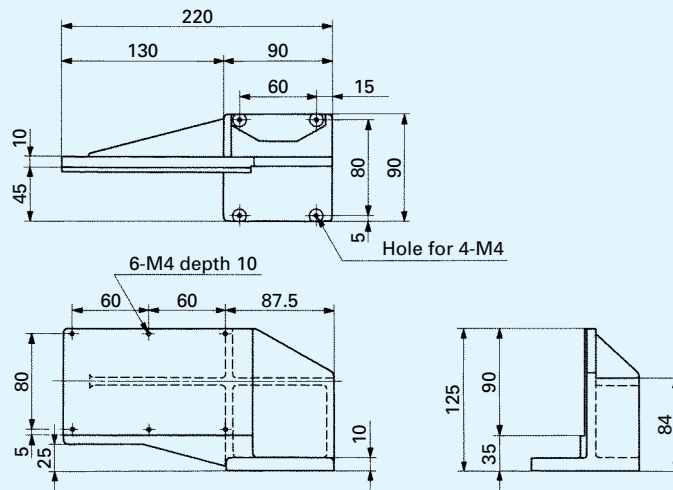
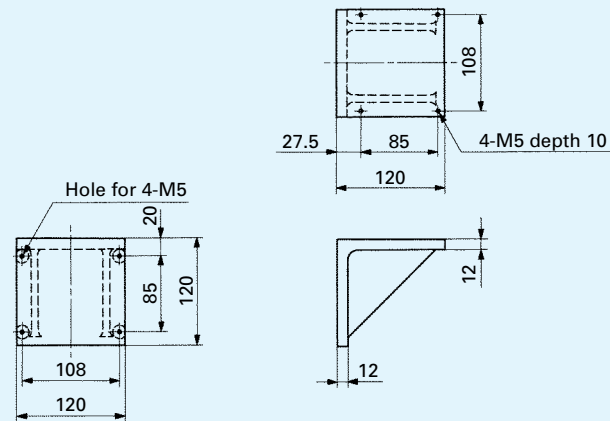
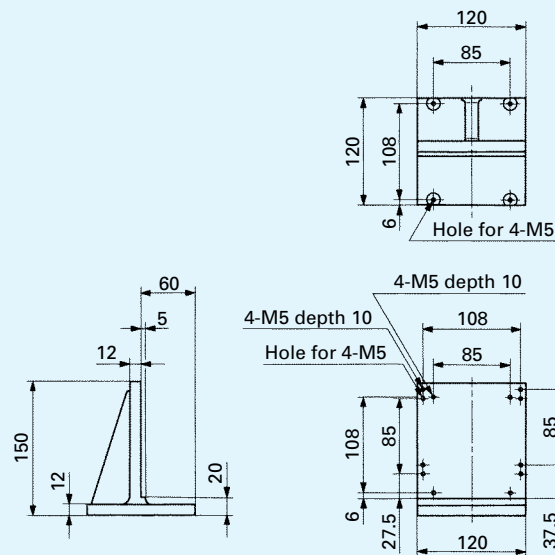

Fig. 2 XY brackets (for TSL90)

●TSL120-AGL



●TSL120-AGI



●TSL120-AGT

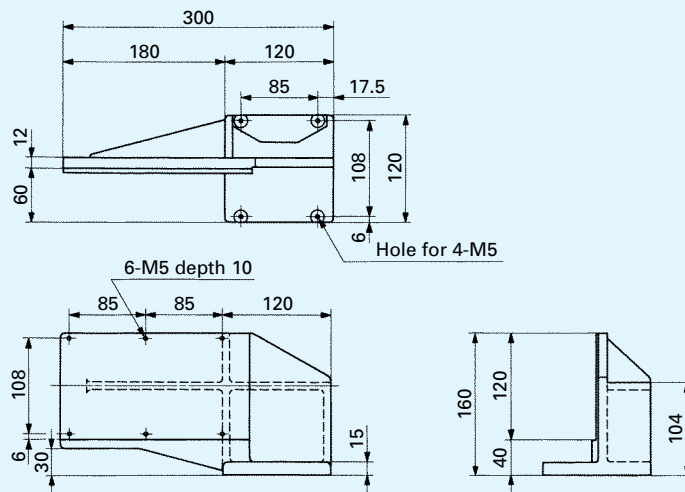

Fig. 3 XY brackets (for TSL120)

System Configuration



Electric devices for  Precision Positioning Table L are specially designed to bring out full performance of the table. A well-balanced system can be constructed by using these devices with the table. Tables 10 to 12 show system configurations of the table with the electric devices when a standard motor is used.

Table 10 System configuration of a table with AC servo motor [configuration with a control unit]

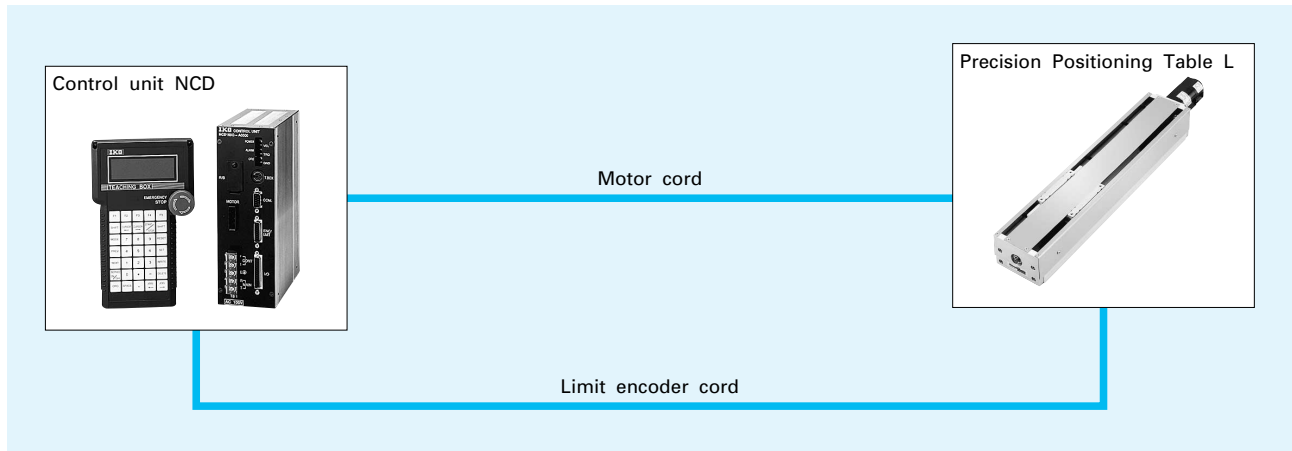

Size	With or without brake	Motor code	Control unit			
			Main body ⁽¹⁾	Teaching box	Motor cord	Limit encoder cord
TSL 90 TSL 120 TSL 170	Without brake	A1, A2	NCD160G-A2006	TAE1050-TB	TAE2065-AM03 (TAE2072-AM03)	TAE2066-AEL03 (TAE2073-AEL03)
TSL 170S TSL 220	With brake	A1B, A2B	NCD160G-A2006 TAE1049-BK ⁽²⁾	TAE1050-TB	TAE2070-AMB03 (TAE2077-AMB03)	TAE2066-AEL03 (TAE2073-AEL03)

Note⁽¹⁾: The control unit based on the CE marking specification (NCD162G-A2006) is also available. Consult  for further information.

⁽²⁾: The code in () indicates a brake regenerative unit type. Connect it to the main body of the control unit.

Remark 1: The codes in () indicate have high bending resistance.

2: The length of each cord is 3 m.

Table 11 System configuration of a table with AC servo motor [configuration with a driver and a programmable controller]

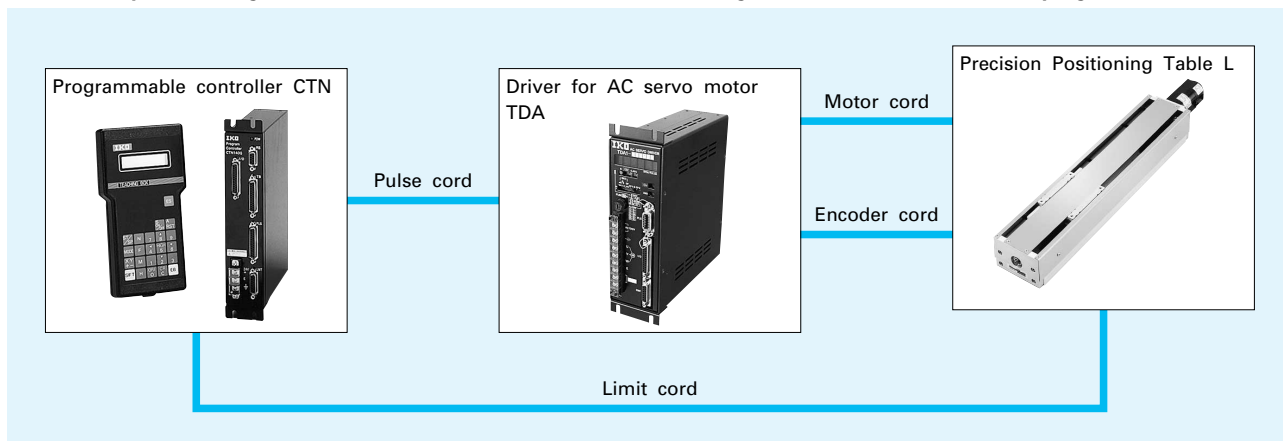

Size	With or without brake	Motor code	Types of applicable electric devices						
			Driver			Programmable controller			
			Main body	Motor cord	Encoder cord	Main body	Teaching box	Pulse cord	Limit cord
TSL 90 TSL 120 TSL 170 TSL 170S	Without brake	A1	TDA1-1004	TAE2052-AM03 (TAE2036-AM03)	TAE2054-AE03 (TAE2038-AE03)	CTN120G	TAE1005-TB	TAE1022-LD03	
						CTN130G	TAE1016-TB	TAE1012-PC	TAE1042-LC03
						CTN140G	TAE1025-TB	TAE1030-PC	TAE1027-LCA03
						CTN150S	TAE1048-TB	TAE1022-LD03	
	With brake	A1B	TDA1-1004BK	TAE2053-AMB03 (TAE2037-AMB03)		CTN120G	TAE1005-TB	TAE1022-LD03	
						CTN130G	TAE1016-TB	TAE1012-PC	TAE1042-LC03
						CTN140G	TAE1025-TB	TAE1030-PC	TAE1027-LCA03
						CTN150S	TAE1048-TB	TAE1022-LD03	
TSL 220	Without brake	A2	TDA1-2004	TAE2052-AM03 (TAE2036-AM03)	CTN120G	TAE1005-TB	TAE1022-LD03		
					CTN130G	TAE1016-TB	TAE1012-PC	TAE1042-LC03	
					CTN140G	TAE1025-TB	TAE1030-PC	TAE1027-LCA03	
					CTN150S	TAE1048-TB	TAE1022-LD03		
	With brake	A2B	TDA1-2004BK	TAE2053-AMB03 (TAE2037-AMB03)	CTN120G	TAE1005-TB	TAE1022-LD03		
					CTN130G	TAE1016-TB	TAE1012-PC	TAE1042-LC03	
					CTN140G	TAE1025-TB	TAE1030-PC	TAE1027-LCA03	
					CTN150S	TAE1048-TB	TAE1022-LD03		

Remark 1 : The codes in () indicate have high bending resistance.

2 : The standard length of the motor cord, encoder cord and limit code is 3 m.

The length of the pulse cord is 1.5 m.

Table 12 System configuration of a table with stepping motor

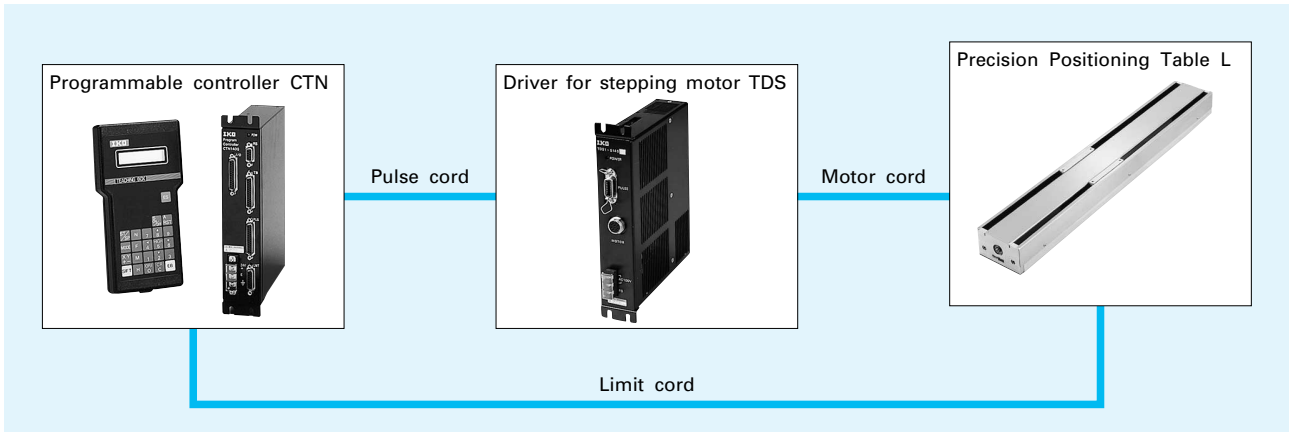

Size	With or without brake	Motor code	Types of applicable electric devices					
			Driver		Programmable controller			
			Main body	Motor cord	Main body	Teaching box	Pulse cord	Limit cord
TSL 90 TSL 120 TSL 170 TSL 170S	Without brake	K5	TDS1-5071	TAE2055-SMC03 (TAE2057-SNC03)	CTN120G	TAE1005-TB	TAE1056-LD03	
					CTN130G	TAE1016-TB	TAE1023-PC	TAE1042-LC03
					CTN140G	TAE1025-TB	TAE1026-PCA	TAE1027-LCA03
					CTN150S	TAE1048-TB	TAE1056-LD03	
			TDS1-5145	TAE2045-SML03 (TAE2059-SNL03)	CTN120G	TAE1005-TB	TAE1022-LD03	
					CTN130G	TAE1016-TB	TAE1012-PC	TAE1042-LC03
	With brake	K5B	TDS1-5145BK	TAE2061-SMBL03 (TAE2062-SNBL03)	CTN120G	TAE1005-TB	TAE1022-LD03	
					CTN130G	TAE1016-TB	TAE1012-PC	TAE1042-LC03
					CTN140G	TAE1025-TB	TAE1030-PC	TAE1027-LCA03
					CTN150S	TAE1048-TB	TAE1022-LD03	
			TDS1-5145	TAE2045-SML03 (TAE2059-SNL03)	CTN120G	TAE1005-TB	TAE1022-LD03	
					CTN130G	TAE1016-TB	TAE1012-PC	TAE1042-LC03
TSL 220	Without brake	K7	TDS1-5145	TAE2045-SML03 (TAE2059-SNL03)	CTN120G	TAE1005-TB	TAE1022-LD03	
					CTN130G	TAE1016-TB	TAE1012-PC	TAE1042-LC03
					CTN140G	TAE1025-TB	TAE1030-PC	TAE1027-LCA03
					CTN150S	TAE1048-TB	TAE1022-LD03	
			TDS1-5145BK	TAE2061-SMBL03 (TAE2062-SNBL03)	CTN120G	TAE1005-TB	TAE1022-LD03	
					CTN130G	TAE1016-TB	TAE1012-PC	TAE1042-LC03
	With brake	K7B	TDS1-5145BK	TAE2061-SMBL03 (TAE2062-SNBL03)	CTN120G	TAE1005-TB	TAE1022-LD03	
					CTN130G	TAE1016-TB	TAE1012-PC	TAE1042-LC03
					CTN140G	TAE1025-TB	TAE1030-PC	TAE1027-LCA03
					CTN150S	TAE1048-TB	TAE1022-LD03	
			TDS1-5145	TAE2045-SML03 (TAE2059-SNL03)	CTN120G	TAE1005-TB	TAE1022-LD03	
					CTN130G	TAE1016-TB	TAE1012-PC	TAE1042-LC03

Remark 1 : The codes in () indicate have high bending resistance.

2 : The standard length of the motor cord and limit cord is 3 m. The length of the pulse cord is 1.5 m.

IKO Precision Positioning Table L

TSL90

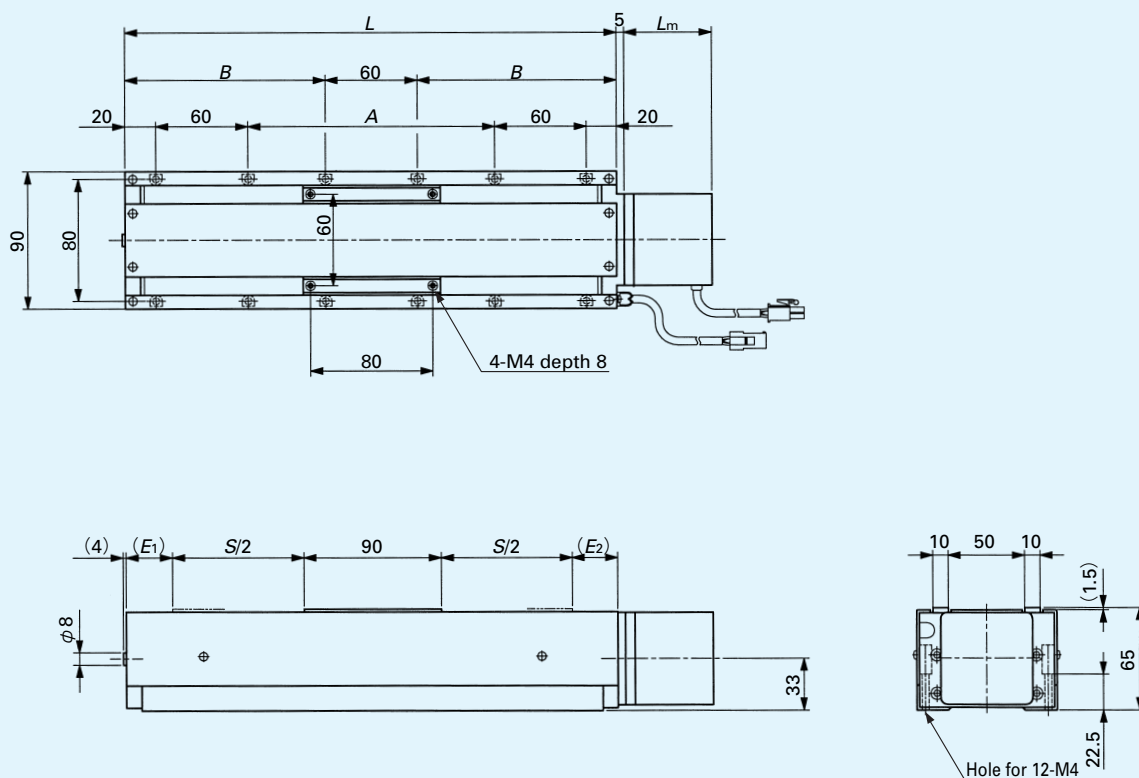

unit : mm

Model number	Stroke length						Dimensions of table			Mass ⁽¹⁾ (Reference) kg
	Without capillary plates			With capillary plates			Total length L	Bed mounting holes A B		
	S	E ₁	E ₂	S	E ₁	E ₂				
TSL 90- 50	50	30	30	—	—	—	200	40	70	2.8
TSL 90-100	100			75	45	40	250	90	95	3.2
TSL 90-150	150			125			300	140	120	3.5
TSL 90-200	200			175			350	190	145	3.9
TSL 90-250	250			225			400	240	170	4.2
TSL 90-300	300			275			450	290	195	4.6

Note⁽¹⁾ : The mass of the motor is not included.

Dimensions of motor L_m

unit : mm

Motor type	AC servo motor	Stepping motor
Motor code	A1	K5
Without brake	94.5	57.5
With brake	135	99.5

1N=0.102kgf=0.2248lbs.
1mm=0.03937inch

IKO Precision Positioning Table L

TSL120

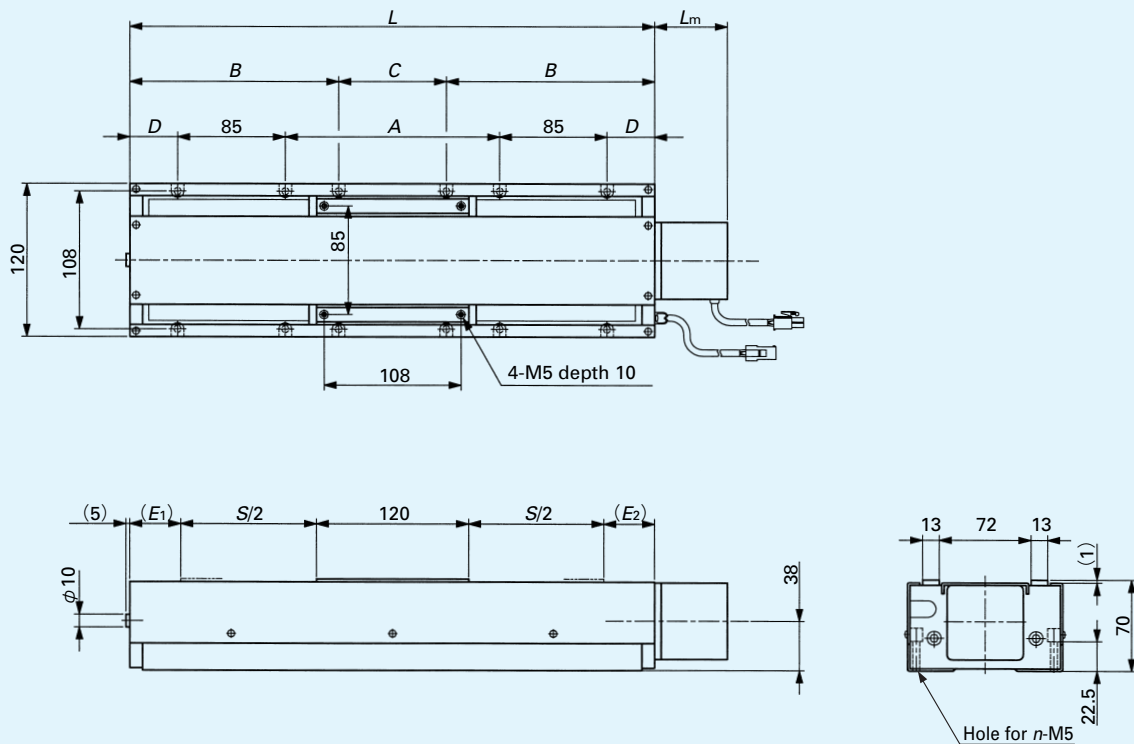

unit : mm

Model number	Stroke length						Dimensions of table					Mass ⁽¹⁾ (Reference) kg	
	Without capillary plates			With capillary plates			Total length L	Bed mounting holes					
	S	E ₁	E ₂	S	E ₁	E ₂		A	B	C	D	n	
TSL 120-100	100	40	40	95	50	35	300	85	107.5	85	22.5	8	6.1
TSL 120-150	150			350			135	132.5	85	22.5	12	6.6	
TSL 120-200	200			400			185	157.5	85	22.5	12	7.1	
TSL 120-250	250			450			235	182.5	85	22.5	12	7.6	
TSL 120-300	300			500			255	207.5	85	37.5	12	8.1	
TSL 120-400	400			600			355	207.5	185	37.5	12	9.1	
TSL 120-500	500			700			455	207.5	285	37.5	12	10.1	
TSL 120-600	600			800			555	207.5	385	37.5	12	11.1	

Note⁽¹⁾ : The mass of the motor is not included.

Dimensions of motor L_m

unit : mm

Motor type	AC servo motor	Stepping motor
Motor code	A1	K5
Without brake	94.5	57.5
With brake	135	99.5

IKO Precision Positioning Table L

TSL170

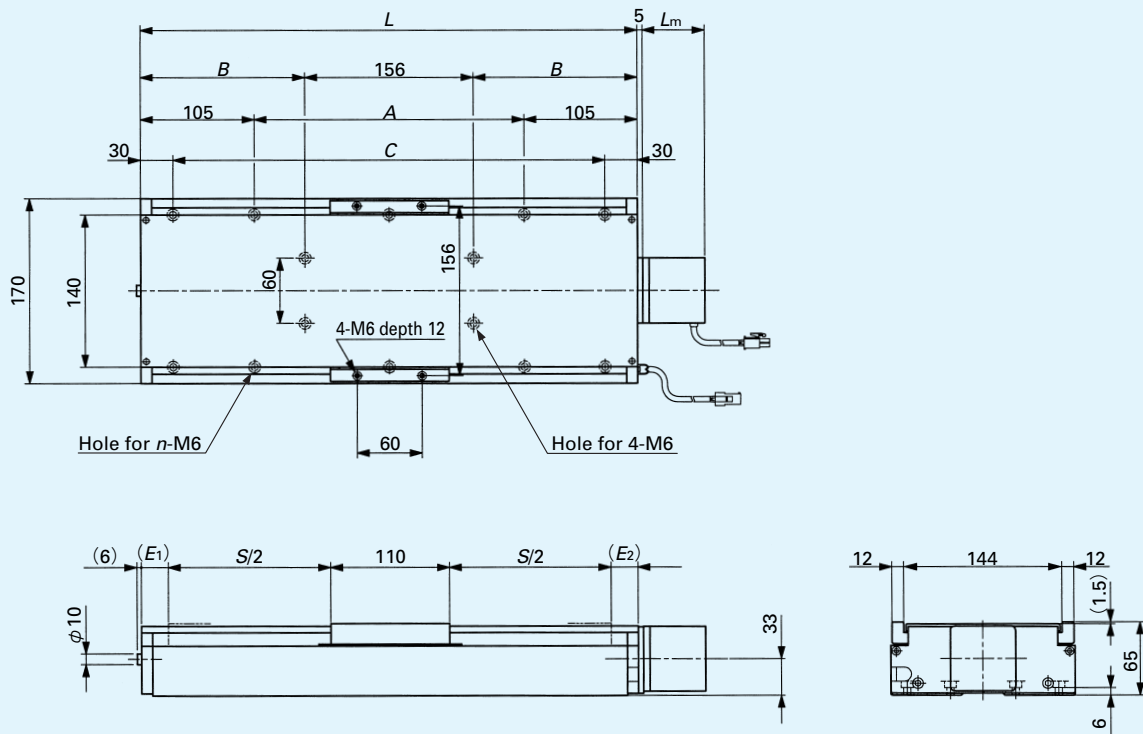

unit : mm

Model number	Stroke length						Dimensions of table					Mass ⁽¹⁾ (Reference) kg
	Without capillary plates			With capillary plates			Total length L	Bed mounting holes				
	S	E ₁	E ₂	S	E ₁	E ₂		A	B	C (Number of pitches X pitch)	n	
TSL 170-150	150	25	25	113	47	40	310	100	77	250	8	7.2
TSL 170-200	200			163			360	150	102	300	8	7.8
TSL 170-250	250			213			410	200	127	350 (2×175)	10	8.4
TSL 170-300	300			263			460	250	152	400 (2×200)	10	9.1
TSL 170-400	400			363			560	350	202	500 (2×250)	10	10.4
TSL 170-500	500			463			660	450	252	600 (2×300)	10	11.6

Note⁽¹⁾ : The mass of the motor is not included.

Dimensions of motor L_m

unit : mm

Motor type	AC servo motor	Stepping motor
Motor code	A1	K5
Without brake	94.5	57.5
With brake	135	99.5

1N=0.102kgf=0.2248lbs.
1mm=0.03937inch

IKO Precision Positioning Table L

TSL170S

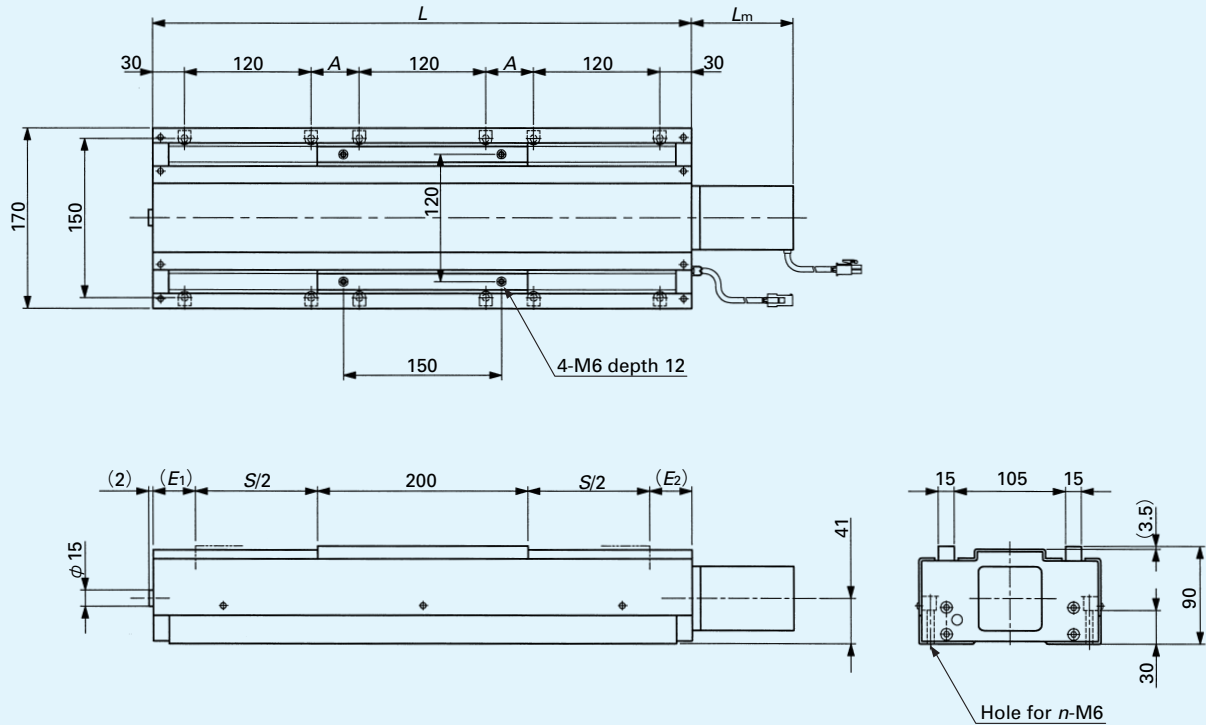

unit : mm

Model number	Stroke length						Dimensions of table			Mass ⁽¹⁾ (Reference) kg
	Without capillary plates			With capillary plates			Total length <i>L</i>	Bed mounting holes		
	<i>S</i>	<i>E</i> ₁	<i>E</i> ₂	<i>S</i>	<i>E</i> ₁	<i>E</i> ₂		<i>A</i> (Number of pitches X pitch)	<i>n</i>	
TSL 170S- 300	300	40	40	275	65	40	580	80	12	14.8
TSL 170S- 400	400			375			680	130	12	16.6
TSL 170S- 500	500			475			780	180	12	18.5
TSL 170S- 600	600			575			880	230	12	20.3
TSL 170S- 800	800			775			1080	330 (2×165)	16	22.2
TSL 170S-1000	1000			975			1280	430 (2×215)	16	22.8

Note⁽¹⁾ : The mass of the motor is not included.

Dimensions of motor *L*_m

unit : mm

Motor type	AC servo motor	Stepping motor
Motor code	A1	K5
Without brake	94.5	57.5
With brake	135	99.5

IKO Precision Positioning Table L

TSL220

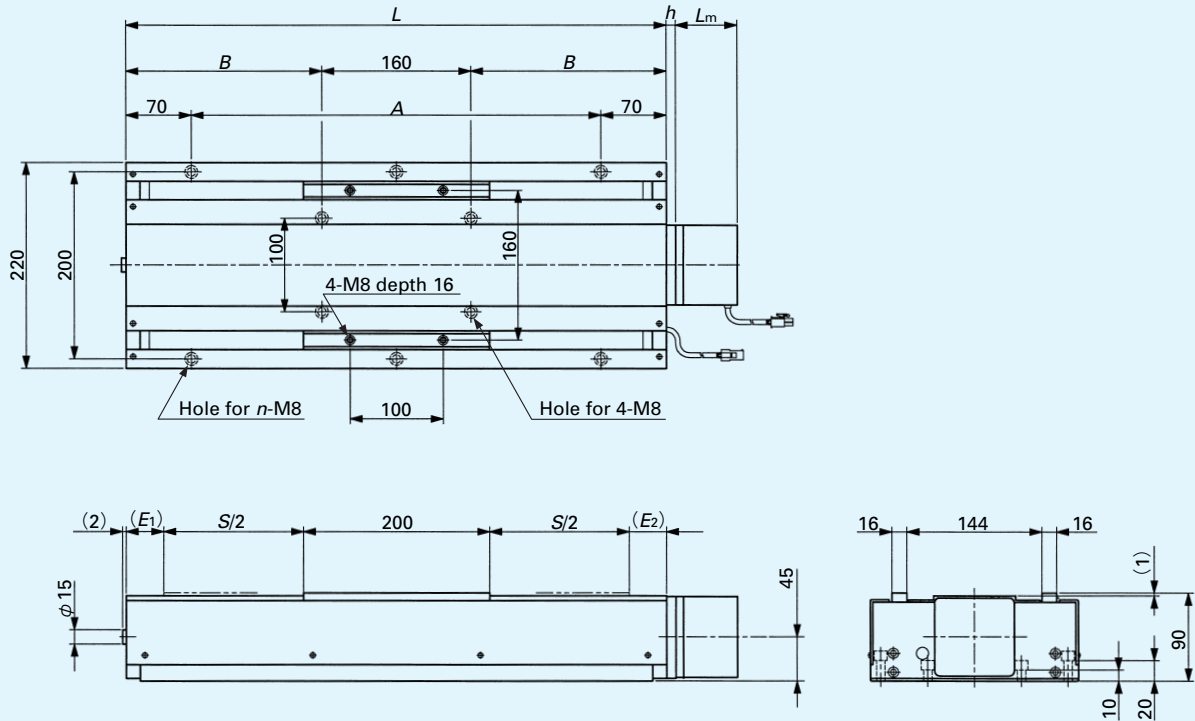

unit : mm

Model number	Stroke length						Dimensions of table				Mass ⁽¹⁾ (Reference) kg
	Without capillary plates			With capillary plates			Total length L	Bed mounting holes			
	S	E ₁	E ₂	S	E ₁	E ₂		A (Number of pitches X pitch)	B	n	
TSL 220- 300	300	40	40	275	65	40	580	440 (2×220)	210	6	20.1
TSL 220- 400	400			375			680	540 (2×270)	260	6	22.5
TSL 220- 500	500			475			780	640 (2×320)	310	6	24.7
TSL 220- 600	600			575			880	740 (4×185)	360	10	27.0
TSL 220- 800	800			775			1080	940 (4×235)	460	10	31.5
TSL 220-1000	1000			975			1280	1140 (4×285)	560	10	36.2

Note⁽¹⁾ : The mass of the motor is not included.

Dimensions of motor

unit : mm

Motor type	AC servo motor		Stepping motor	
Motor code	A2		K7	
Dimensions	h	L _m	h	L _m
Without brake	—	96.5	10	66
With brake	—	136	10	119

1N=0.102kgf=0.2248lbs.
1mm=0.03937inch



NIPPON THOMPSON CO., LTD.

Head office : 19-19 Takanawa 2-chome
 Minato-ku, Tokyo 108-8586, Japan
 Phone : +81 (0)3-3448-5850
 Fax : +81 (0)3-3447-7637
 E-mail : ntt@ikonet.co.jp
 URL : <http://www.ikont.co.jp/eg/>
 Plant : Gifu, Kamakura

Nippon Thompson Co., Ltd.

- ASEAN REPRESENTATIVE OFFICE
 586 Luang Road, Pomprab
 Pomprab Satrupai, Bangkok
 Thailand 10100
 Phone: +66 (0)-2623-3699
 Fax: +66 (0)-2623-0716
 E-mail: iko@anet.net.th
- CHINA REPRESENTATIVE OFFICE
 Shanghai Apollo Business Center 619
 1440 Yan An C. Road, Shanghai 200040
 People's Republic of China
 Phone: +86 (0)21-6248-1120
 Fax: +86 (0)21-6249-6835

IKO International, Inc.

- 91 Walsh Drive
 Parsippany, NJ 07054
 U.S.A.
 Phone: +1 973-402-0254
 Toll Free: 1-800-922-0337
 Fax: +1 973-402-0441
 E-mail: eco@ikonet.co.jp
- 500 East Thorndale Avenue
 Wood Dale, IL 60191
 U.S.A.
 Phone: +1 630-766-6464
 Toll Free: 1-800-323-6694
 Fax: +1 630-766-6869
 E-mail: mwo@ikonet.co.jp
- 20170 South Western Avenue
 Torrance, CA 90501
 U.S.A.
 Phone: +1 310-609-3988
 Toll Free: 1-800-252-3665
 Fax: +1 310-609-3916
 E-mail: wco@ikonet.co.jp
- 2150 Boggs Road, Suite 100
 Duluth, GA 30096
 U.S.A.
 Phone: +1 770-418-1904
 Toll Free: 1-800-874-6445
 Fax: +1 770-418-9403
 E-mail: seo@ikonet.co.jp
- 8105 N. Beltline Road
 Suite 130, Irving, TX 75063
 U.S.A.
 Phone: +1 972-929-1515
 Toll Free: 1-800-295-7886
 Fax: +1 972-915-0060
 E-mail: swo@ikonet.co.jp

Nippon Thompson Europe B.V.

- Sheffieldstraat 35-39
 3047 AN Rotterdam
 The Netherlands
 Phone: +31 (0)10-4626868
 Fax: +31 (0)10-4626099
 E-mail: nte@ikonet.co.jp
- Mündelheimer Weg 56
 40472 Düsseldorf
 Germany
 Phone: +49 (0)211-414061
 Fax: +49 (0)211-427693
 E-mail: ntd@ikonet.co.jp
 Donaustauer Str. 200
 93059 Regensburg
 Germany
 Phone: +49 (0)941-447737
 Fax: +49 (0)941-447747
- 2 Vincent Avenue, Crownhill
 Milton Keynes Bucks MK8 OAB
 United Kingdom
 Phone: +44 (0)1908-566144
 Fax: +44 (0)1908-565458
 E-mail: sales@iko.co.uk
- Autovia Madrid-Barcelona, Km. 43,700
 Polig. Ind. AIDA, A-8, Ofic. 2, 1^a
 19200-Azuqueca de Henares
 Guadalajara, Spain
 Phone: +34 949-263390
 Fax: +34 949-263113
 E-mail: nts@ikonet.co.jp
- Roissypole Le Dôme
 2 rue de La Haye
 BP 10950 Tremblay en France
 95733 Roissy C. D. G. Cedex
 France
 Phone: +33 (0)1-48165739
 Fax: +33 (0)1-48165746
 E-mail: ntf@ikonet.co.jp

Although all data in this catalog has been carefully compiled to make the information as complete as possible, NIPPON THOMPSON CO., LTD. shall not be liable for any damages whatsoever, direct or indirect, based upon any information in this catalog. NIPPON THOMPSON CO., LTD. makes no warranty, either express or implied, including the implied warranty of merchantability or fitness for a particular purpose.